



FOREMAN NITE CAPS

TEMPORARY PIPE PLUGS





Venting plugs are standard features on all but the smallest Foreman Nite Caps and are used to relieve the pipe of any naturally occurring pressure buildup.

PARTS LIST		
Item No.	Description	No. Required
1	Outer Disc	1
2	Inner Disc with 1 Inch Nut	1
3	Hex Nut Cast into Item 2	1
4	Rubber Gasket	1
5	Steel and Fiber Washers	1
6	Hex-Head Bolt	1
7	Retaining Ring for Bolt	1
8	Pipe Cap	1
9	Pipe Nipple	1
10	Pipe Plug	1

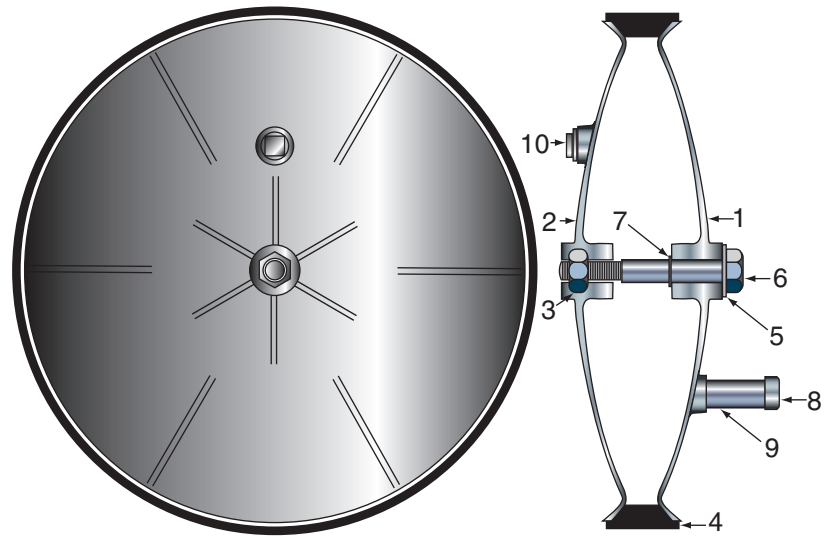

SDR SIZE PIPE SPECIFICATIONS					
Standard Sizes		Approx. Wt.		ID of Pipe Ranges	
inches	mm	lbs	kg	inches	mm
16	406	20	9.1	16.5 to 17	419.1 to 431.8
18	457	28	12.8	18.5 to 19	469.9 to 482.6
20	508	37	16.8	20.5 to 21	520.7 to 533.4
22	559	42	19.1	22.5 to 23	571.5 to 584.2
24	610	46	20.9	24.5 to 25	622.3 to 635.0
26	660	51	23.2	26.5 to 27	673.1 to 685.8
28	711	65	29.5	28.5 to 29	723.9 to 736.6
30	762	74	33.6	30.5 to 31	774.7 to 787.4
34	864	108	49.0	34.5 to 35	876.3 to 889.0
36	914	118	53.6	36.5 to 37	927.1 to 939.8
40	1016	134	60.8	40.5 to 41	1028.7 to 1041.4
42	1067	145	65.8	42.5 to 43	1079.5 to 1092.2
48	1219	181	82.2	48.5 to 49	1231.9 to 1244.6

RUGGED

Field tested by major companies and practical pipeliners, Foreman Nite Caps have been proven both durable and long-lasting. The rubber used on the Foreman Nite Caps can withstand a temperature range from -40 °F to 260 °F. These Foreman Nite Caps can also be vented when desirable.

WIDER RANGE OF PIPE IDs

Now covering a wider range of pipe ID's, Foreman Nite Caps can be used for most 1/2" thick casings, as well as other casings like SDR pipes, or even metric. All of these are possible with the addition of a new rubber extrusion from APS. Check tables for details.



FOREMAN NITE CAPS

Foreman Nite Caps keep unwanted items out of your pipes.

Foreman Nite Caps are available in 2 to 48 inch sizes, guard against water, mud, rocks, skids, bottles, cans and other accumulation found in both new and old pipelines and keep animals and small children from entering, as well.

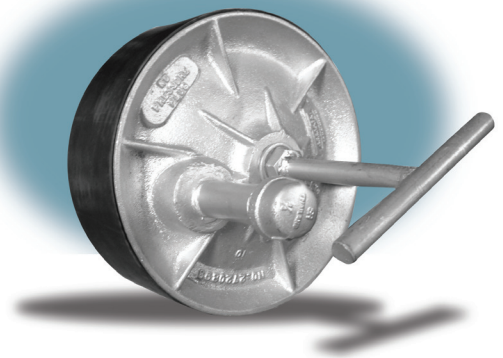
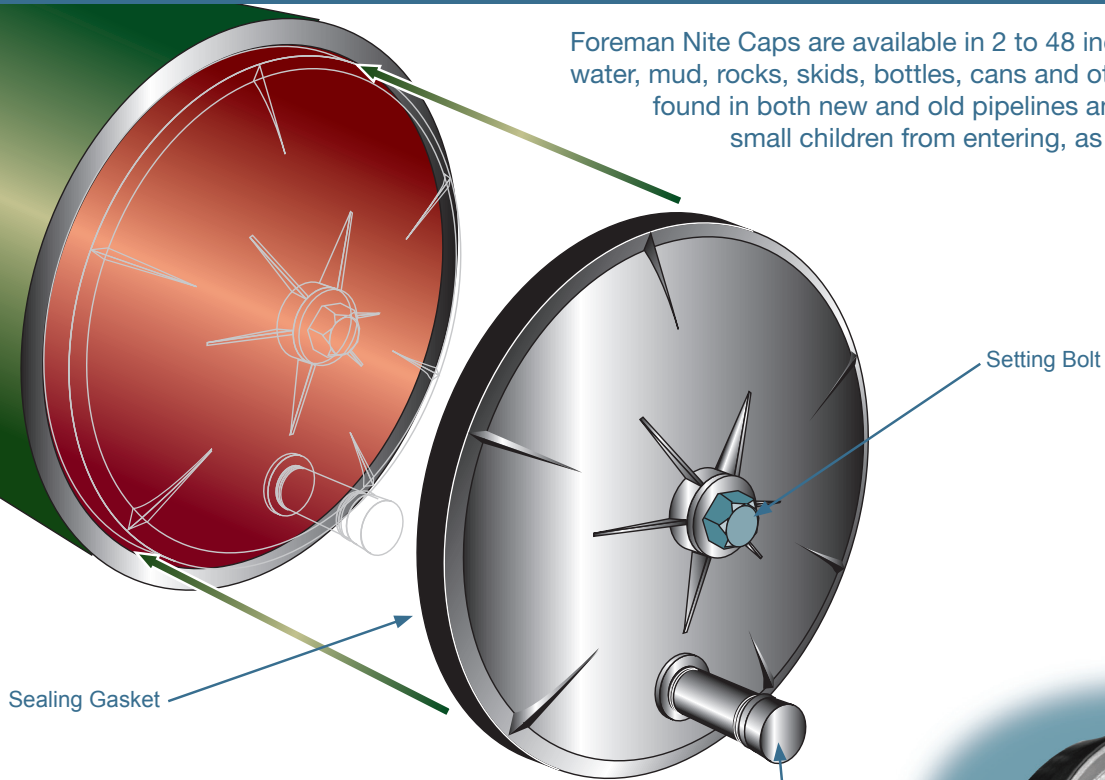

10 Inch (T-Handle Optional)

SPECIFICATIONS

Standard Sizes		Approx Wt.		ID of Pipe Ranges			
inches	mm	lbs	kg	inches		mm	
2	51	1.76	0.8	2	to 2.5	50.8	to 63.5
3	76	3	1.4	2.75	to 3.25	69.9	to 82.6
4	102	4	1.9	3.8125	to 4.375	96.8	to 111.1
5	127	5	2.3	4.8125	to 5.375	122.2	to 136.5
6	152	5	2.3	5.625	to 6.3125	142.9	to 160.3
8	203	7	3.2	7.6875	to 8.375	195.3	to 212.7
10	254	10	4.6	9.625	to 10.25	244.5	to 260.4
12	305	16	7.3	11.75	to 12.375	298.5	to 314.3
14	356	16	7.3	13.25	to 13.75	336.6	to 349.3
16	406	20	9.1	15.25	to 15.75	387.4	to 400.1
18	457	24	10.9	17.25	to 17.75	438.2	to 450.9
20	508	32	14.6	19.25	to 19.75	489.0	to 501.7
22	559	37	16.8	21.25	to 21.75	539.8	to 552.5
24	610	40	18.2	23.25	to 23.75	590.6	to 603.3
26	660	45	20.5	25.25	to 25.75	641.4	to 654.1
28	711	58	26.4	27.25	to 27.75	692.2	to 704.9
30	762	67	30.4	29.25	to 29.75	743.0	to 755.7
34	864	100	45.4	33.25	to 33.75	844.6	to 857.3
36	914	110	49.9	35.25	to 35.75	895.4	to 908.1
40	1016	125	56.7	39.25	to 39.75	997.0	to 1009.7
42	1067	135	61.3	40.875	to 41.375	1038.2	to 1050.9
48	1219	170	77.2	47.25	to 47.75	1200.2	to 1212.9

LIGHTWEIGHT AND EASY TO INSTALL

Because Foreman Nite Caps are made of lightweight metal, one man can install a 30 inch model without assistance. A few turns of a single bolt force disc plates together, pressing a rubber gasket against pipe walls as a barrier to unwanted items. Foreman Nite Caps, however, are not pressure holding devices.

ECONOMICAL

Foreman Nite Caps outperform inefficient caps, sacks, sheet iron plates and canvas covers, and are reusable indefinitely. Replacement parts such as gaskets and other components are available.

OTHER QUALITY PRODUCTS AVAILABLE

- Kleerband® Flange Band Protectors
- Radolid® Bolt and Nut Protection Caps
- Casing Insulators and End Seals
- Innerlynx® - Modular Mechanical Seals
- IsoJoint® - Monolithic Isolators
- Inspect-A-Lift® - Adjustable Pipe Support System
- Standard Isolating Gasket Kits
- Integra SSA® - Cathodic Isolating Gasket Kits
- Gal-vo-plast® Wall Sleeves
- UBolt-Cote®
- Safety Spray Shields



PO Box 60399 • Lafayette, Louisiana 70596-0399
800-315-6009 • 337-233-6116 • FAX 337-232-3860
E-Mail: sales@apsonline.com • Website: www.apsonline.com



Distributed by:

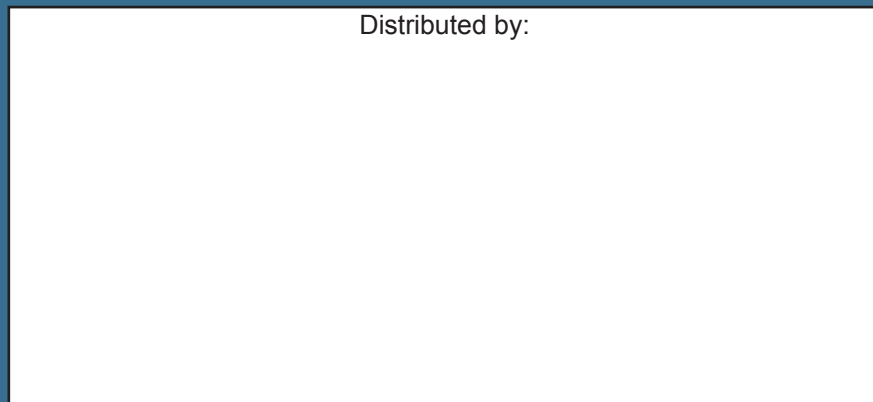

Advance Products & Systems, LLC is not responsible for errors printed in this brochure.

Advance Products & Systems, LLC shall repair or replace (within the limitations of such applicable express written warranty as may be issued by it) any product or portions thereof, which prove to be defective in workmanship or material for a period of 12 months from shipment date. The foregoing in lieu of all warranties, express or implied, and all other obligations or liabilities on the part of APS, on account of the product which it may sell. In no event shall APS be liable for consequential or special damages: nor except as it may otherwise specifically agree in writing, installation, or other work which may be done upon or in connection with the product by APS/the distribution/dealer or others. THE LIMITED WARRANTIES PROVIDED IN THIS AGREEMENT AND THE OBLIGATIONS AND LIABILITIES OF APS ARE THE ONLY WARRANTIES MADE BY APS AS TO THE PRODUCT. APS MAKES NO EXPRESS OR OTHER IMPLIED WARRANTIES, BY COURSE OF DEALING, USAGE OF TRADE, MERCHANTABILITY, FITNESS FOR A PARTICULAR USE (WHETHER GENERAL OR SPECIFIC), OR OTHERWISE.